



P.A.M.

“ THE MISSING LINK ”

MORE PRODUCTIVITY + LESS INJURIES

IN LINE WITH VISION 2020 PLAN

Positioner-Actuator-Manipulator

Features & Specifications

- ◆ Mount 15 lbs chipping hammer to 35 lbs rivet buster hydro-demo lances, rock drill and other various tools
- ◆ Designed to push the tool against the surface, eliminates dead blow
- ◆ Water nozzle for dust control
- ◆ Air powered over hydraulic and electric
- ◆ 100° swing lock hydraulic knuckle boom
- ◆ 4 caster wheels and 2 removable 12” wheels
- ◆ 3 outriggers for stability
- ◆ Multi-function electronic controls
- ◆ Air consumption 50 to 60 CFM @ 90 P.S.I.
- ◆ Total weight without tool = 1150 lbs. (525 Kg)
- ◆ Frame size 32” X 72” without removable wheels



Proud member of:
**INTERNATIONAL
CONCRETE REPAIR
INSTITUTE**



Benefits

- ◆ Proven production boost 2 to 3 times
- ◆ Get fast and consistent production on walls and **overhead** repair
- ◆ Eliminates hammer dead blows, vibration and weight
- ◆ Eliminates wear and tear on workers
- ◆ Greater job focus and comfort = less fatigue, more productivity
- ◆ More flexibility in job costing and better delivery time
- ◆ Chipping is no longer a punishment
- ◆ Quick return on investment
- ◆ Self contained, no harmful emissions
- ◆ Easier recruiting, less turnover
- ◆ Low maintenance and easily transported





P.A.M.
"THE MISSING LINK"

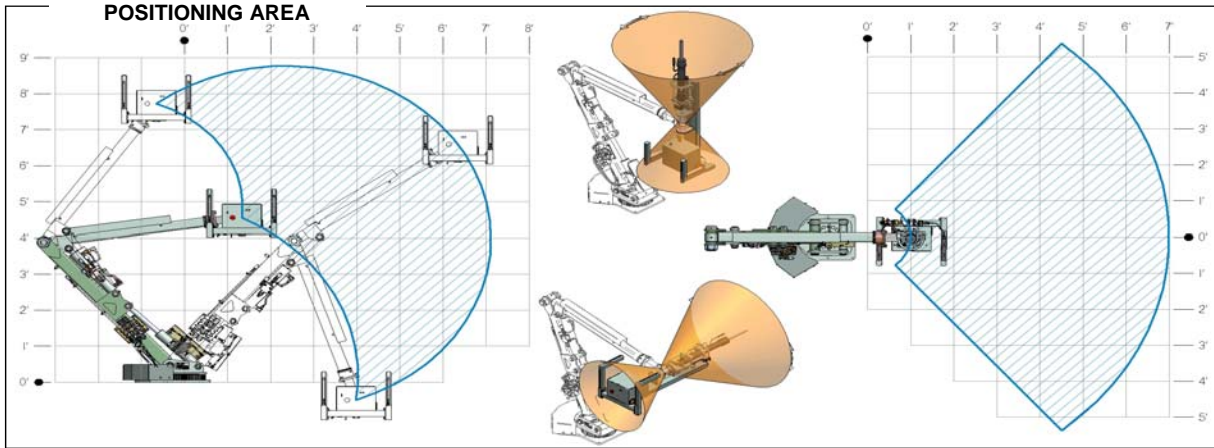

**SEE IT IN ACTION
AT
www.rnpind.com
OR CALL FOR A DEMO
888 697 5355**

